

DAELIM

OWNER'S MANUAL

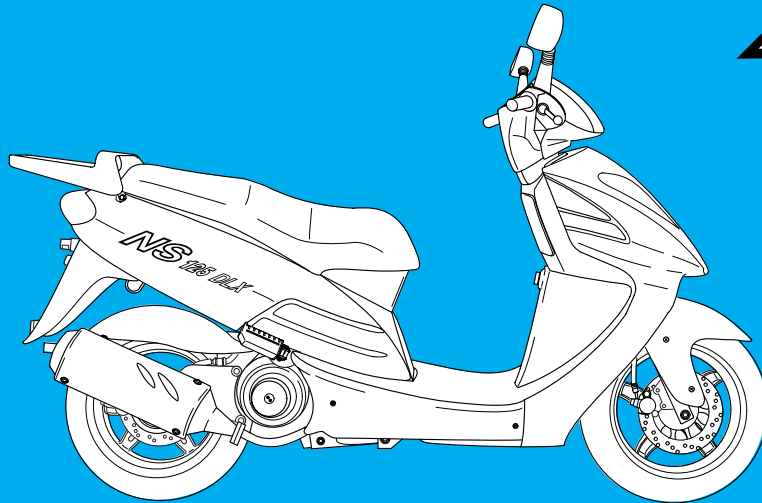

NS 125 DLX

CONTENTS

SPECIFICATION	3
OPERATION INSTRUCTION	4
SAFETY PRECAUTIONS	4
PRIOR TO STARTING VEHICLE.....	5
CORRECT ATTIRE	5
OPERATION.....	6
CARGO.....	6
MODIFICATION	7
MUFFLER	7
PARTS LOCATION	8
METER READING AND USAGE	10
METER	10
INDICATOR LAMP	10
HOW TO SET CLOCK	11
SWITCH OPERATION	12
MAIN SWITCH	12
STARTER BUTTON.....	12
HEADLIGHT	13
WINKER SWITCH	13
HORN BUTTON	14
HAZARD SWITCH.....	14

EQUIPMENT USAGE	14
STEERING LOCK	14
SEAT LOCK	15
INNER BOX	15
TRUNK	16
DOCUMENT STORAGE AREA.....	16
BAG HOLDER	17
HANDPHONE CHARGER.....	17
CORRECT DRIVING OPERATION	18
STARTING THE ENGINE.....	18
IF ENGINE CANNOT BE STARTED	20
AFTER STARTING ENGINE.....	21
PROPER DRIVING METHODS.....	22
STOPPING	23
SELF INSPECTIONS BEFORE OPERATION	25
INSPECTION OF CONCERNED AREA	26
BRAKE INSPECTION	26
FUEL CHECK.....	27
TIRE INSPECTION	28
ENGINE OIL LEVEL CHECK	29
LIGHTS AND WINKER INSPECTION	29
BACK MIRROR INSPECTION	30

FUEL LEAK INSPECTION	30
LICENSE PLATE INSPECTION	30
MAINTENANCE	30
MAINTENANCE SCHEDULE	31
MAINTENANCE PRECAUTIONS	33
BRAKES	33
BRAKE HOSE, PIPE LEAKAGE, DAMAGE, ASSEMBLY STATE	35
BRAKE PAD WEAR.....	35
CHANGING ENGINE OIL	36
WHEEL REMOVAL	37
SPARK PLUG.....	39
BATTERY INSPECTION	40
FUSE REPLACEMENT	41
BULB REPLACEMENT	42
AIR CLEANER ELEMENT INSPECTION	44
SIDE STAND INSPECTION	45
CABLE RUBBER PART INSPECTION	45
NOTABLES FOR CAR WASHING	45
STORAGE GUIDE.....	46
FRAME AND ENGINE NUMBER	47

SAFE DRIVING	48
PREPARATION BEFORE DRIVING	48
DRIVING METHOD	49
DRIVING POSITION	49
PRECAUTION WHEN DRIVING.....	51
STARTING.....	52
TURNING METHOD	54
PRINCIPLE OF TURN	54
EFFECT OF SPEED	54
3 POSITIONS OF TURNING	55
TURNING METHOD	56
PRECAUTION WHEN TURNING	57
BRAKING METHOD	58
BASIC PRINCIPLE OF BRAKE(FRICTION FORCE).....	58
RESTRAINT OF BRAKE EFFECT (INERTIA)	58
BRAKING METHOD	59
COMPARISION OF BRAKING DISTANCE.....	59
IMPACT WHEN COLLISION	59
WIRING DIAGRAM	60

SPECIFICATION

ITEM	DATA	ITEM	DATA
LENGTH×WIDTH×HEIGHT(mm)	1,970×700×1,110	IGNITION SYSTEM	C.D.I
WHEEL BASE(mm)	1,350	BATTERY CAPACITY	12V6AH(MF TYPE)
GROUND CLEARANCE(mm)	130	FUEL CAPACITY(l)	7.5
SEAT HEIGHT(mm)	765	TIRE SIZE	FR. 120 / 70 - 12 53K
WEIGHT(kgf)	110		RR. 130 / 70 - 12 62K
PASSENGER	2	SUSPENSION	FR. TELESCOPIC
ENGINE TYPE	OIL COOLED/AIR COOLED 4 STROKE 4VALVE		RR. UNIT SWING OIL DAMPER
PISTON DISPLACEMENT(cc)	124.9	BRAKE	FR. HYDRAULIC DISK
BORE AND STROKE(mm)	56 × 50.7		RR. HYDRAULIC DISK
STARTING SYSTEM	START MOTOR / KICK	SPARK PLUG	CR8EH-9
TRANSMISSION TYPE	V - MATIC	FUSE(A)	15

OPERATION INSTRUCTION

This manual describes matters pertaining to correct operation, safe operation and simple maintenance of the vehicle you purchased.

To ensure more comfortable and safer operation, make sure to read this manual carefully prior to operation.

- The photographs and drawings shown in this manual may differ from those of actual vehicles due to changes in vehicle specifications and modifications made.
- This vehicle is designed for 2 riders including the operator.

CAUTION

- Do not use polluted gasoline.
Using polluted gasoline will cause rust inside the fuel tank, and will close the supply of fuel to the carburetor, leading to an improper engine starting or may cause serious damage to an engine.
- Do not use polluted or low-grade oil.
Always use genuine oil to protect and extend vehicle performance and its life span.
- If any failure occurs due to the use of polluted gasoline or oil, such failure will be excluded from being eligible for repairs under the warranty.

SAFETY PRECAUTIONS

- Careful driving and the wearing of proper attire and safety equipment are the most important factors in the safe operation of the scooter. Please obey traffic regulations and do not be hurried and careless.
- Many new vehicle owners operate their newly purchased vehicles with great care and attention to safety factors. However, after becoming accustomed to the operations are often discarded, which can lead to accidents. Please don't let this happen to you and always approach the operation of your vehicle with the safety considerations needed.
When operating the vehicle, always keep in mind and obey the notes of precaution printed on the "Safety Precaution Label" attached to the vehicle.

- Always wear helmet.
- Observe posted speed limits.
- Park vehicle away from people(especially children) as the muffler can get very hot.
- For safety, do not illegally modify the vehicle.
- If exposed to direct sunlight for a long period of time, the visual display panel may temporarily be fogged.
- Regularly conduct specified maintenance inspections.
<Maintenance Inspection Points>
Brakes, Tires, Oil, Lights, Horn, Instruments

PRIOR TO STARTING VEHICLE

- Read user's manual carefully.
- Conduct maintenance checks prior to operation.
- Always maintain vehicle in clean status and carry out specified maintenance checks.
- Make sure to stop engine and stay away from fire when fueling.
- Exhaust gas contains harmful substance such as carbon monoxide, Start engine in well-ventilated places.

CORRECT ATTIRE

- Always make sure to wear helmet for safety. Wear gloves and safety goggles.
- Do not wear uniforms which might hinder operation. It is dangerous if the uniform is caught by brake lever.

A helmet should always be worn and the helmet chin strap should be securely fastened.

Correct shirts or jackets with tight-fitting sleeves should be worn,

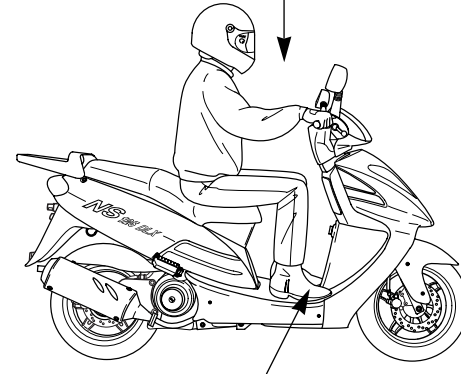

Shoes should fit properly, and shoes having little or no heel should be worn.

OPERATION

- Operators should naturally fix bodies to keep smooth driving.
- Please check whether or not you are unnaturally strained and strung up.
- Driving pose has a great influence on safe operation.
Please always maintain the center of your body in the middle of seat, Especially do not sit at the rear seat because it may lessen the weight of front wheel and cause trembling steering wheel.
- Passengers should accurately fix bodies using both hands and put both feet on floor panel.

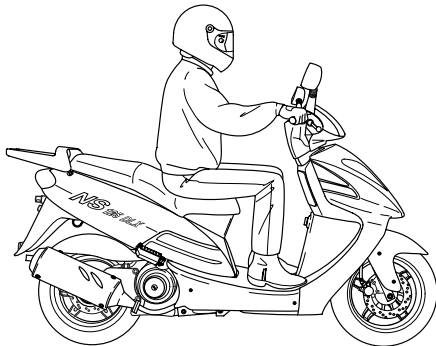

CARGO

When carrying cargo, you must keep in mind that operating the vehicle, especially when turning, will be different. Make sure not to overload the vehicle with goods as this can make the vehicle unstable during operation.

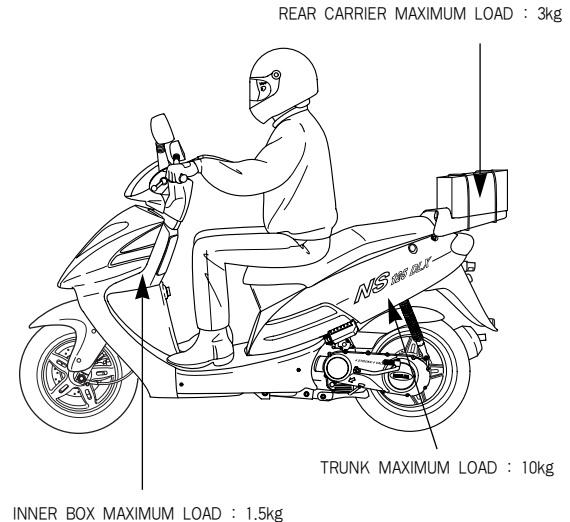

CAUTION

- Only load cargo in or on designated areas as placing or fastening cargo to other areas can cause damage to the vehicle.
- Do not place articles between the frame body cover and engine as this can burn the goods.

MODIFICATION

Modification of vehicle structure or function deteriorates manipulability or causes exhaust noise to become louder shortening the vehicle life. These modifications are not only prohibited by law but also are the acts harmful to other people. Modifications are not covered by warranty.

MUFFLER

- Pay particular attention to fellow passenger so that he/she can prevent getting burnt by the hot muffler during travel.

PARTS LOCATION

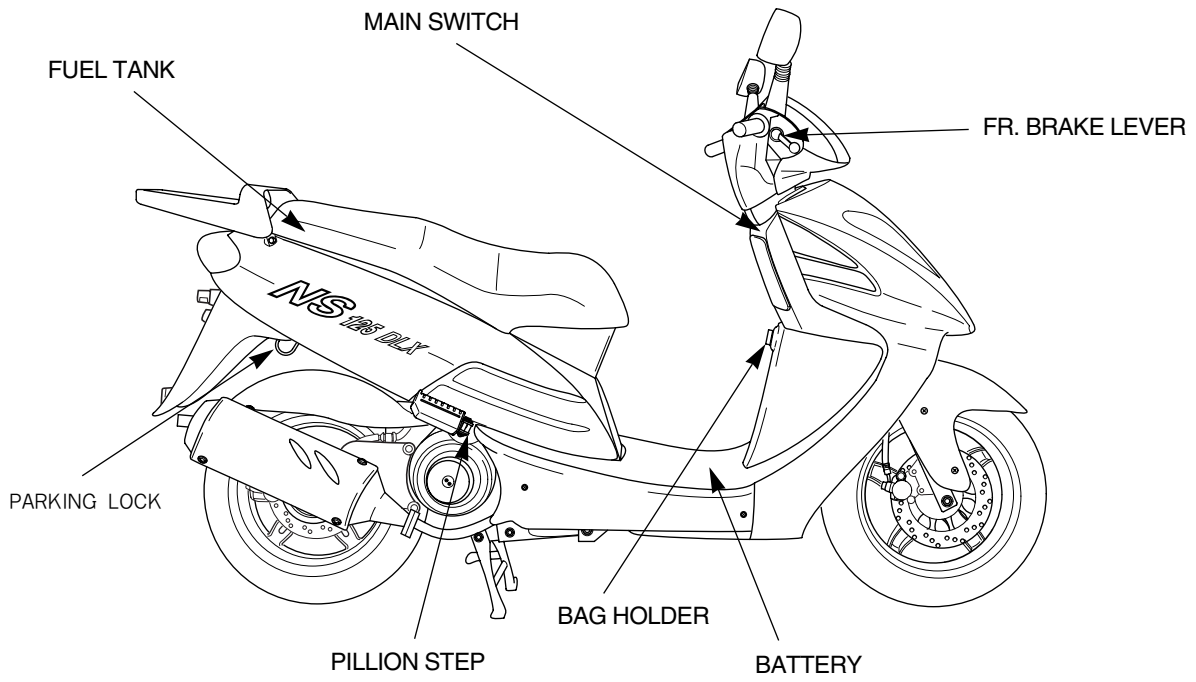

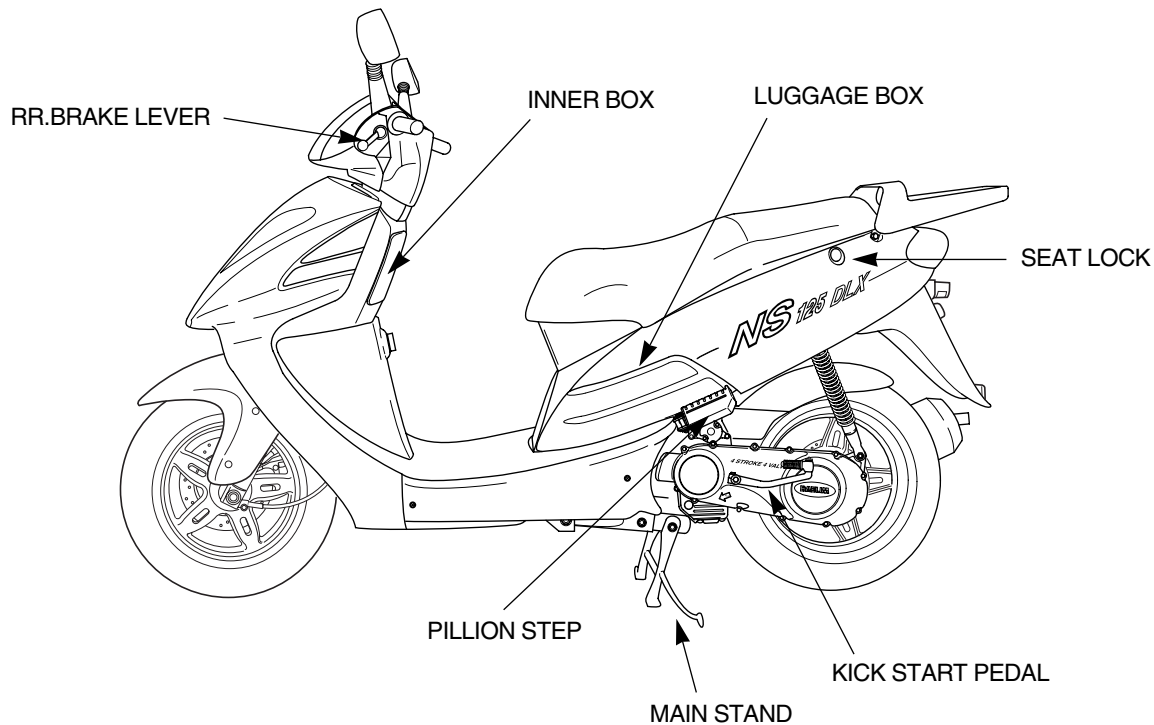

METER READING AND USAGE

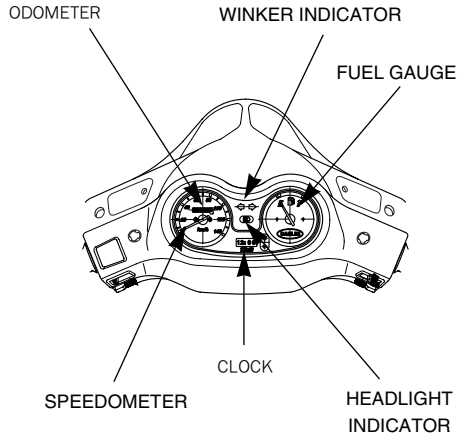

METER

<SPEEDOMETER>

Indicates driving speed. Maintain legal speed limits to ensure safe operation.

<ODOMETER>

Indicates total distance in kilometers travelled by the vehicle.

<FUEL GAUGE>

The fuel gauge indicates the gasoline level inside the fuel tank.(The needle will indicate the amount of gasoline in the fuel tank whether the main switch is turned to OFF or On position.)

Gasoline should be put in the fuel tank as soon as possible if the needle is resting in the red area. When the needle is in the red area, roughly 1, 2 liters of gasoline can be put in the vehicle to fill tank.

INDICATOR LAMP

<WINKER INDICATOR>

If the winker switch is operated, the winker indicator flashes in union with the flashing of the turn signals.

<CLOCK>

- Current time shows below meter.
- You can use other clock battery.

CAUTION

- Long exposure to sunray can make clock digit invisible.

<CHANGING CLOCK BATTERY>

- Separate the front handle cover.
- Open the cover of clock battery below meter and change battery.
- If you feel difficult, please contact authorized maintenance shops for inspection.

HOW TO SET CLOCK

TIME EX)



TIME SETTING

- Push button B 4 times. (12 : P)
- Push button A and set time you want.
- If completed, push button B for setting.

MINUTE SETTING

- Push button B 5 times. (: 30)
- Push button A and set time you want
- If completed, push button B for setting.

DATE EX)



MONTH SETTING

- Push button B 2 times. (1)
- Push button A and set time you want.
- If completed, push button B for setting.

DAY SETTING

- Push button B 3 times. (21)
- Push button A and set time you want
- If completed, push button B for setting.

DATE/TIME CHECKING

EXAMPLE 1

If you push button A one time, time will be changed into date.

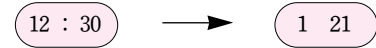

After checking it, push button B to keep it back.

EXAMPLE 2

If you push button B one time, time will be changed into date and automatically restored into time.

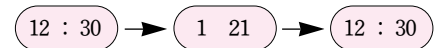

After checking, it, push button B 5 times to keep it back.

SWITCH OPERATION

MAIN SWITCH

MAIN SWITCH

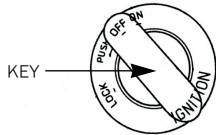
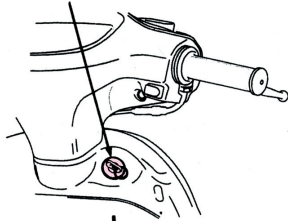

1. On.... Starts engine. Key can not be pulled out.
2. OFF....Stops engine. Key can be placed in or taken out of the main switch.
3. LOCK....Locks handle bars. Key can be placed in or taken out of the main switch.

CAUTION

- Do not manipulate main switch key during operation. If the main switch key is placed on “Off” or “Lock” position, all electrical system will not function. Never operate the main switch key during travel as it might cause unexpected accidents, If it is necessary to remove the main switch key, stop the vehicle first prior to removing.
- When you park the vehicle and leave it, please lock handle bars and take out the key.
- If the key is left in “ON” position without starting engine, battery is discharged.
- Do not use a number of keys together with a metal key holder. The keys and the key holder may cause scratches or other damage to the cover while operating the vehicle. (Recommend cloth or leather key holders)

STARTER BUTTON

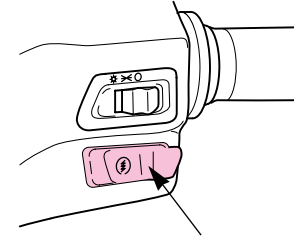

STARTER BUTTON

The engine is started pressing this button when pressed in a state where the main switch key is placed to an ON position and the brake lever is pulled.

CAUTION

- The engine will not start if the brake lever is not pulled.



HEADLIGHT

<TURNING ON HEADLIGHT>

Put main switch key in “ON” position and turn on headlight switch.

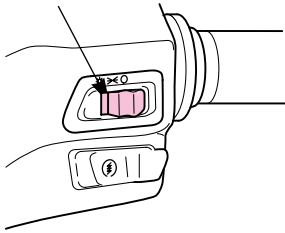
HEADLIGHT SWITCH



SWITCH POSITION	FUNCTION
 (H)	Headlight, taillight, position lamp and meter lights on.
 (P)	Position lamp, taillight, and meter lights on.
○ (OFF)	Light turned off.

<HEADLIGHT HIGH/LOW BEAM SWITCH>

High beam or low beam can be operated by the use of high/low beam switch.

HEADLIGHT HIGH/LOW BEAM SWITCH

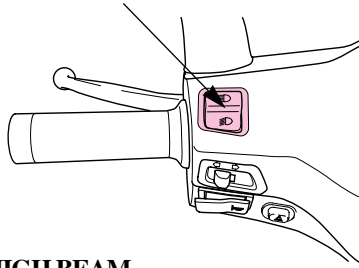

HIGH BEAM

 (HI) used when needing extra light.

LOW BEAM

 (LO) used when other vehicles are present, in the city, etc.

CAUTION

- Use the high beam only in the suburban road or when the usage of the high beam not hinder the safe driving of the car ahead.

WINKER SWITCH

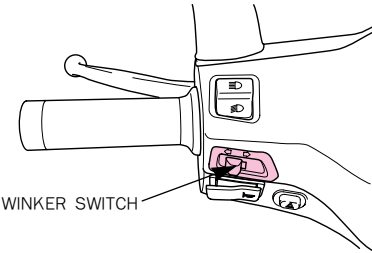

WINKER SWITCH

If this switch is turned on when the main switch is in an ON position, the winker will operate.

- ⇨ (R)....used when making a right turn.
- ⇦ (L)....used when making a left turn.

CAUTION

- The winker switch does not automatically turn back to its original position after completing the turn. Please set the switch back to its center position after turning.

HORN BUTTON

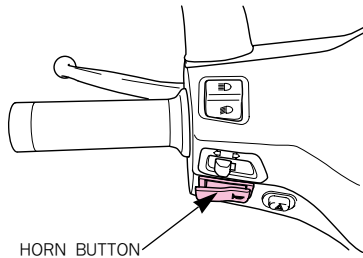

The horn is sounded if the horn button is pressed when the main switch is in an ON position.

HAZARD SWITCH

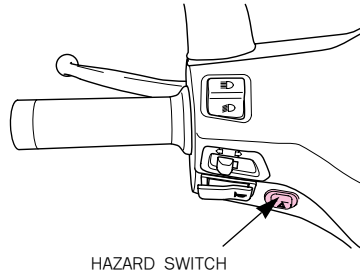

When the emergency light button is pressed with the main switch in "ON" position, the winker lamp will start blinking.

EQUIPMENT USAGE

STEERING LOCK

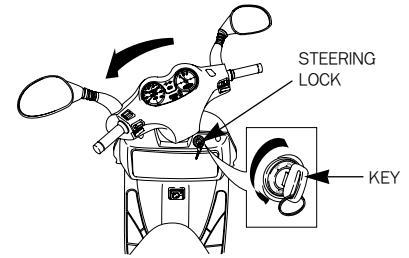

<LOCKING>

To lock the steering, turn the handlebars all the way to the left, turn the key to LOCK while pushing in. Remove the key.

<UNLOCKING>

To unlock the steering, turn the key to the OFF position.

WARNING

- Do not turn the key to LOCK while riding the motorcycle; loss of vehicle control will result.

SEAT LOCK

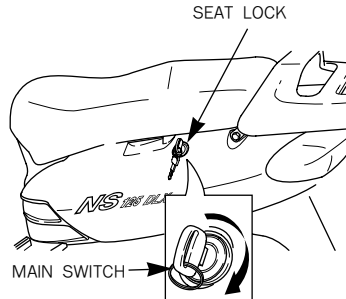

<LOCKING>

- The seat automatically locks when the seat is pushed in its downward position,
- Lightly pull upward on the seat to make sure the seat has been properly locked.

<UNLOCKING>

- Turn the seat lock switch to the right using the main switch key.

CAUTION

- As the seat automatically locks, take special care not to accidentally leave the key in the trunk.
- Driving with unlocked seat lock may cause danger.

INNER BOX

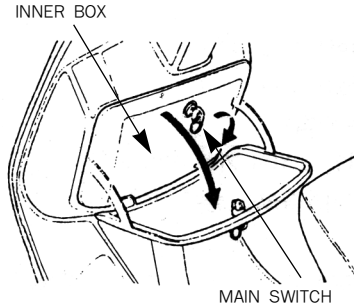

<LOCKING>

Turn the inner box switch to the right using the main switch key. In this state, close the cover, turn the key to the left and then remove the key.

<UNLOCKING>

Turn the inner box switch to the right with the main switch key and the inner box will easily open.

INNER BOX MAXIMUM LOAD: 1.5kg

CAUTION

- Do not place valuable or fragile goods in the inner box.
- Make sure to remove important items out of the inner box when washing the vehicle as water can enter the inner box.

TRUNK

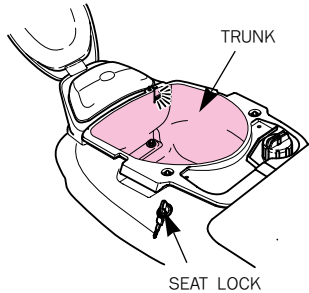

- There is a trunk under the seat.
- The seat is opened to gain access to the trunk by using the main switch key on the seat lock.
- The lamp inside the trunk will be turned on if the seat is opened.

TRUNK MAXIMUM LOAD:10kg

CAUTION

- Make sure that the seat is securely locked after closing the seat.
- An unlocked seat can hinder the operation of the vehicle.
- The temperature inside the trunk rises due to heat from the engine. Do not place foodstuffs and other articles that can be damaged easily by heat. Also do not place flammable materials in the trunk.
- Do not place valuable or fragile goods in trunk.
- As water can enter the trunk when washing, make sure to remove articles that can be damaged by water.
- Do not load uncloseable size of helmet and thing in the trunk, otherwise, the battery can be discharged with the trunk lamp on.

DOCUMENT STORAGE AREA

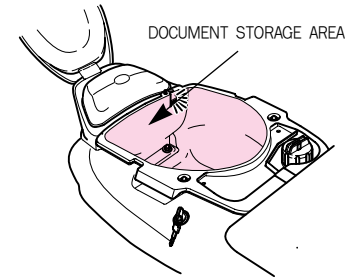

- There is a document storage area on the bottom of the seat.
- Store the owner's manual and the maintenance notebook in this area.

BAG HOLDER

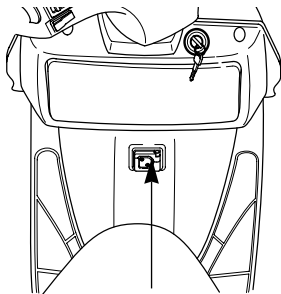

BAG HOLDER

- For ease in carrying bags and similar items, they should be hung from the bag holder which is fitted for this purpose.
- When using the bag holder, place it in the open position and return it to the normal position when not in use.

CAUTION

- Do not attempt to carry very heavy or bulky loads since this would affect the stability and steering characteristics of the scooter.

HANDPHONE CHARGER

HANDPHONE CHARGER

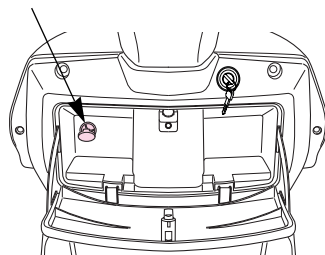

- The main switch key is used to open the inner box.
- Open the charge socket cap, insert the handphone plug into the socket.
- Close the inner box.
- Turn the main switch to an ON position.
- When the charging is completed, open the inner box and remove the handphone plug.

CAUTION

- The charging of the handphone must be done with the main switch placed in ON.
- Usage of if the handphone plug for other purpose (for example, lantern or ciga jack) may cause the battery discharging.
- Driving the vehicle during charging the handphone may cause damage and failure of the handphone.

CORRECT DRIVING OPERATION

- Make sure to check the oil, gasoline, etc., before starting the engine.
- Please ensure that the main stand is in a down position when starting the engine.

CAUTION

- Make sure that the rear brake is holded when starting the engine to prevent an unexpected quick start of the vehicle.
- Drive with care for both safety reasons and longer vehicle life.
- For 1 month (or 1,000km) after purchasing the vehicle, drive moderately avoiding fast starts and fast acceleration.

STARTING THE ENGINE

Always follow the proper starting procedure described below.

- This motorcycle is equipped with a side stand ignition cut-off system.
- The engine cannot be started if the side stand is down.
- Always be ensure that you operate the engine starting controls with the scooter on its stand.

WARNING

- Never run the engine in an enclosed area. The exhaust contains poisonous carbon monoxide gas that can cause loss of consciousness and lead to death.
- While the scooter is on its stand you should NEVER apply full throttle:if the rear wheel touches the ground the scooter would set off at full speed. (Remember that the scooter has a centrifugal automatic speed control)

- 1 Lock the rear wheel.

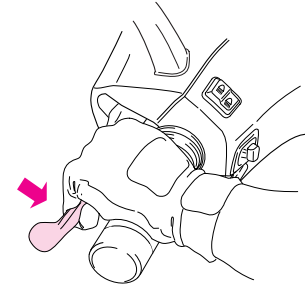

- 2 Turn the main switch to an ON position.

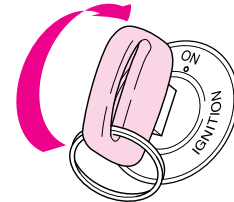

- 3 Start engine with cell or kick.

<USING THE ELECTRIC START(CELL)>

- Press the starter button without rotating the starter grip (opening the throttle).

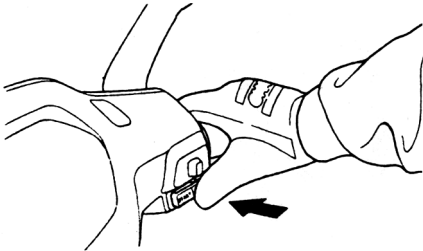

CAUTION

- Immediately release the starter button as soon as the vehicle has started.
- Do not press the starter button when the engine is running.
This can damage the starting motor.

- If the engine is hot and does not start after pressing the starter button for 3~4 seconds, rotate the throttle grip to 1/8~1/4 of a rotation and try again. This will allow easy starting

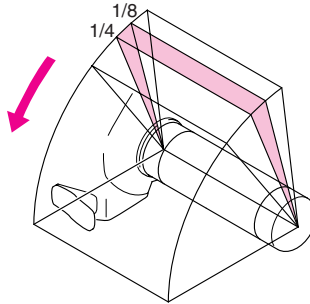

- It is possible that starting will be more difficult if the vehicle has not been used for a long period of time or if the fuel hole is plugged up (starting problems even when there is sufficient fuel in the fuel tank may be an indication of a plugged fuel hole).
When this happens, do not rotate the throttle grip and try the starter button a few times.

CAUTION

- Do not keep the starter button pressed for more than 5 seconds at a time. Release the starter button for approximately 10 seconds before pressing it again.

<WITHOUT ELECTRIC START(KICK)>

- Erect main stand and hold rear brake lever and then step kick starter pedal strongly.

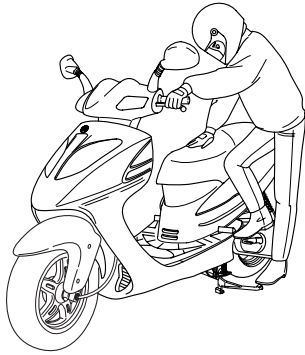

CAUTION

- Make sure to place kick starter in its original position after the engine has been started.
- Be sure to erect main stand and side stand when starting.
- Do not use the starter button and the kick-starter pedal simultaneously.

- 4 When the engine is cold (morning or winter or the vehicle has not been used for a long period of time) let the engine idle for a short period allow the engine to warm up.

CAUTION

- Keep holding rear brake until start.
- Exhaust has contains harmful substance such as carbon monoxide.
Start engine in well-ventilated places.

IF ENGINE CANNOT BE STARTED

If engine cannot be started or vehicle does not move, check the followings.

- Is there fuel in fuel tank?
- Are you operating in accordance with the instructions given in owner's manual?
- Is fuse not cut?
- Is starter motor running?
- If starter motor is not running due to battery consumption, try starting motor by using kick start technique.

AFTER STARTING ENGINE

1 Fold the main stand.

- Push the vehicle forward to fold the main stand and make sure that the brake lever does not become released during this operation.



CAUTION

- Do not excessively open the throttle until you actually start the driving operation of the vehicle.

2 Get on the vehicle.

- Mounting should be done from the left side, and you should sit squarely on the seat. Leave either one foot or both feet planted on the ground.

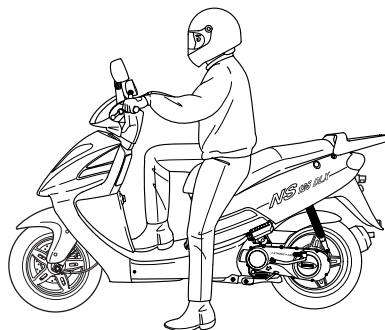

CAUTION

- Keep holding rear brake lever before starting.

- ### 3 Release the squeezing tension on the rear brake lever and slowly begin to rotate the throttle grip to allow for a slow and easy start.

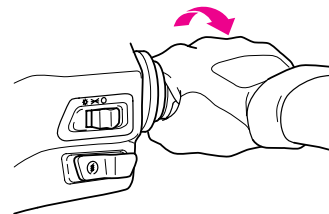

CAUTION

- A quick rotating of the throttle grip will cause the vehicle to move suddenly forward.
- If the engine RPM isn't decreased after the throttle grip return to its original position, stop operating and inspect it in the closest authorized repair center.

PROPER DRIVING METHODS

- Before entering traffic, use the correct turn signal to forward other drivers of your intentions.

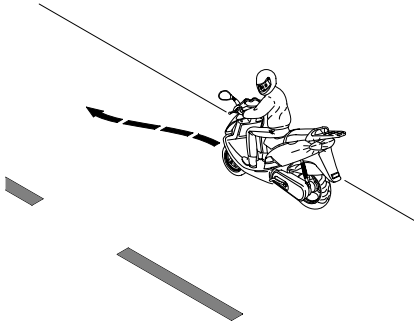

Speed is controlled by the operation of the throttle grip.

- If the throttle grip is rotated.....

The speed of the vehicle increases. Please rotate the throttle grip slowly. When climbing a hill, the throttle grip need to be rotated further to give the vehicle more power.

- If the throttle grip is allowed to rotate back.....

Speed decreases. This can be done slowly or quickly, depending on how quickly you need to decelerate.

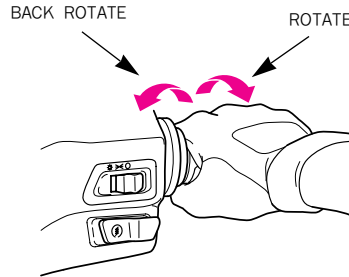

Work the front and rear brakes together.

- Allow the throttle grip to rotate back to its beginning position and then squeeze the brake levers.
- If is best to operate the brakes by first lightly squeezing the brake levers and then changing to a more firm squeeze.

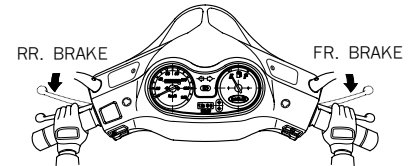

CAUTION

- If only one of the brakes is used, it is possible for the vehicle to experience sliding.

The brakes should never be suddenly applied and the handle bars should never be suddenly turned.

- Sudden braking or turning can cause the vehicle to slide and tip over.
- It is especially dangerous to perform sudden braking on wet roads or in rainy weather as the tires can lose traction and slip easily.



Special care in driving should be taken during rainy weather.

- More braking distance is needed when driving on wet roads or in the rain. Reduce speed and be sure to initiate the braking operation sooner than when driving in normal conditions.
- On downgrades, allow the throttle grip to rotate back to its initial position to reduce speed, and apply the brakes and drive slowly down the hill.
- It is possible for the brakes to temporarily lose operative ability after driving through a puddle or when driving in the rain. To ensure that the brakes are operating properly, slow down (after checking for other vehicles) and while driving slowly, lightly apply the brakes to rid the brakes of any excess water and to dry them.
- Be extremely careful when driving in the snow or on icy roads. When driving in these conditions, both the tires lose much of their traction and the rear tire can slip when opening the throttle.

STOPPING

- 1 When approaching the desired stopping area.
 - Activate the proper turn signal, and after checking for other vehicles, slowly turn into the area in which you want to stop.
 - Allow the throttle grip to rotate completely back and apply the front and rear brakes. The brake light will shine to alert vehicles in back of you that you are stopping.

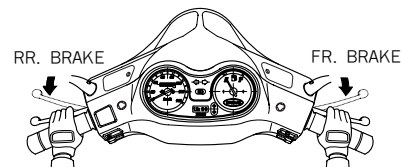

2 After the vehicle has come to a complete stop.

- Return the turn signal switch to the center position and turn the main switch to OFF. This will turn the engine off.

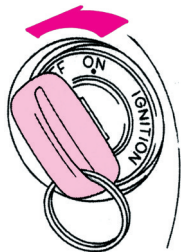

CAUTION

- Do not rotate the main switch key while driving. If the main switch is turned to an OFF or LOCK position, the electrical system will not operate. Operating the main switch key while driving can be very hazardous. Only turn the main switch key to OFF or LOCK positions after completing stopping the vehicle.

3 Dismount on the left side and lower the main stand on a flat surface.

- Be sure to park in an area that is free of traffic. Also, the vehicle can tip over if the main stand is not placed on a stable and flat surface.
- The main stand is lowered by grasping the handle bars with the left hand, holding the rear carrier with the right hand, and stepping firmly on the stand with the right foot. In this position, lift the rear carrier upward, which will secure the main stand.

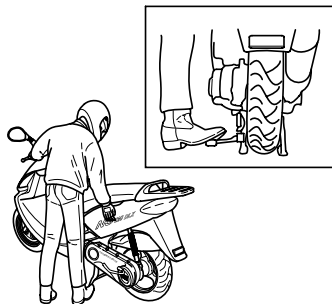

4 To prevent theft, be sure to lock handle bars when parking.

CAUTION

- Park in a safe area that will not block traffic. When you parked the vehicle after driving, make sure foot the vehicle beyond man's reach because engine and muffler are still hot.
- Park the motorcycle on firm, level ground to prevent it from failing over.
- If you must park on a slight incline, aim the front of the motorcycle uphill to reduce the possibility of rolling off the side stand or overturning.

SELF INSPECTIONS BEFORE OPERATION

Self inspect the vehicle and have regular maintenance inspections for increased safety and the prevention of accidents. Regular maintenance inspections should be performed even if the vehicle has not been used for a long period of time.

Self inspections before operation should be performed on a daily basis prior to operating the vehicle.

- Inspections of concerned Area
- Brake inspection
- Fuel check
- Tire inspection
- Engine oil level check
- Lights and turn signal inspection
- Back mirror inspection
- Fuel leak inspection
- License plate inspection
- Throttle grip inspection

CAUTION

Observe safety rules when conducting inspections.

- Exhaust gas contains harmful substance such as carbon monoxide. Do not carry out inspections on vehicle in closed places, or in poorly ventilated places, with engine running.
- Conduct inspections on flat, solid ground with the stand erected.
- Be careful of burns when conducting inspections immediately after engine is stopped because the engine and muffler are hot.
- Stop engine and remove the key prior to the vehicle maintenance service.
- Use appropriate types of tools.

- If you are unable to correct trouble even after you make adjustment or correction, contact authorized maintenance shops, dealers or designated repair shops for necessary inspection and repairs.

INSPECTION OF CONCERNED AREA

- Check areas which caused for concern when last operating the vehicle.
- If happened, contact authorized maintenance shops for necessary inspection and repairs.

BRAKE INSPECTION

<BRAKE LEVER FREE PLAY>

Lightly squeeze the brake levers until tension is felt to check for an appropriate amount of free play. No free play in the brake levers or overly loose brake levers are indication of a problem in the brake system.

BRAKE LEVER FREE PLAY: 10-20mm

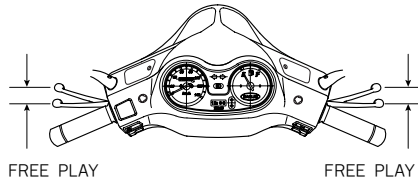

CAUTION

- Specified brake lever free play must be maintained. Excessive free play may cause long stopping distance, brake operational fault and slow reacting time resulting in the dangerous situation and insufficient free play may cause short stopping distance and damage brake system(pad, lining, etc.)

<CHECK OF BRAKE FLUID>

This is checked by placing the vehicle on its main stand on a flat surface. Make sure that the handle bars are at a horizontal level. Check to see if the fluid are below the LOWER level.

If brake fluid are significantly low, this may indicate that there are leakage in the brake system. Inspect the brake hoses to check for leaks.

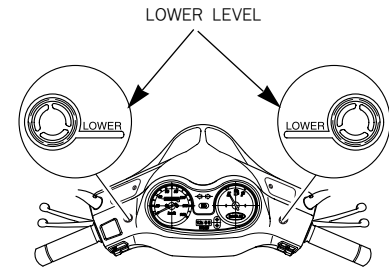

CAUTION

- If the brake fluid is significantly lower than the specified level, inspect not only brake fluid but also check the front brake pad for wear.

FUEL CHECK

<CHECK>

- Check gasoline to see if there is a sufficient amount of gasoline to reach your destination.
- If the fuel gauge needle indicates E mark (red portion), fill fuel tank with gasoline as soon as possible.

RESERVE FUEL CAPACITY : 1.2 l

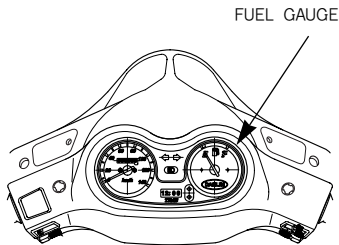

<REFUELING>

- Use the main switch key to open the SEAT.
- Turn the fuel tank cap counterclockwise, and remove it.
- Fill the tank with gasoline until it reaches the bottom of the level plate.
- Be sure to set the fuel tank cap to the right position.

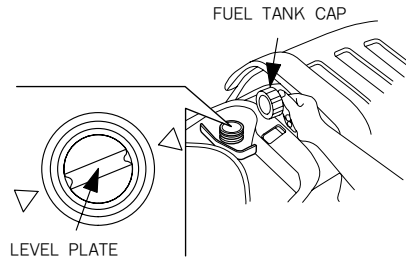

CAUTION

- Gasoline is extremely flammable and is explosive under certain conditions. Refuel in a well-ventilated area.
- Make sure to stop engine and stay away from fire when refueling.
- Do not fill gasoline past the level plate. Gasoline may leak out of the fuel tank when replacing the fuel tank cap if too much gasoline is put in the fuel tank.
- Don't fill low grade gasoline. Using it can cause damage (bending, getting worn, etc.) to combustion chamber and parts of fuel.
- Do not close the fuel cap with excessive strength. It may cause the damage of the cap and the rubber packing resulting in the leak of fuel and may cause fire in case of electrical short or the overturn of the vehicle.
- Avoid repeated or prolonged contact with skin or breathing of vapor.
KEEP OUT OF REACH OF CHILDREN.

TIRE INSPECTION

<AIR PRESSURE CHECK>

Check for an appropriate level of air pressure by examining how the tire sits on the ground. If you notice any abnormalities in the shape of the tire with regard to the area contacting the ground, use a tire gauge to check tire pressure and adjust the tire pressure to the appropriate level.

<TIRE PRESSURE>

SIZE	FRONT	120/70-12 53K	
	REAR	130/70-12 62K	
AIR PRESSURE (kg/cm ²)	1 PERSON RIDING	FRONT	1.75
		REAR	2.00
	2 PERSON RIDING	FRONT	1.75
		REAR	2.25

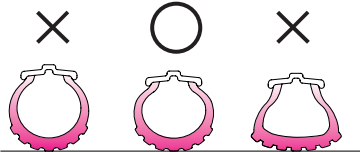

<CRACKS/DAMAGE>

Check tire tread and sides for cracks and damage.

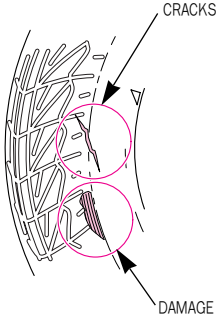

<ABNORMAL WEAR>

Check tire tread for signs of abnormal wear.

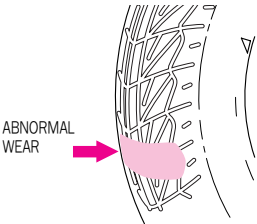

<FOREIGN MATTER>

Check tire tread and sides for nails, rocks, etc. That might have become wedged in the tire.

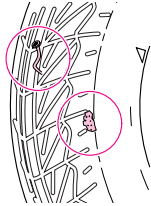

<TREAD DEPTH>

- Check the wear indicator (wear limit marking) to see if there is an insufficient amount of tread remaining.
- If the indicators are visible, replace tire with a new one.

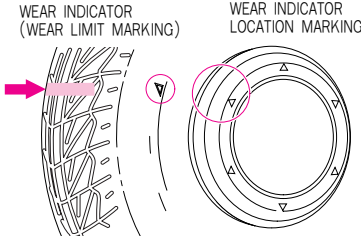

CAUTION

- If air pressure is inadequate or if there are cracks, damage or abnormal wear on tires, it may cause trembling steering wheel and flat tire.
- Insufficient air pressure may cause the heavy steering wheel making handling difficult, fuel over consumption and the excessive wear of tire outer area and excessive air pressure may cause easier wheel handling and lower fuel consumption. But it may also cause the excessive wear of tire center area.
- This vehicle is equipped with tubeless tires. If you have flat tires, please contact authorised maintenance shops for inspection.

ENGINE OIL LEVEL CHECK

Check the engine oil level each day before riding the motorcycle.

The oil level must be maintained between the upper and lower level marks on the sight-glass

- Stand the motorcycle on the main stand on level ground.
- Start the engine and let it idle for approximately 2~3 minutes.
- Check the engine oil level.
- If required, add the specified oil. Do not overfill.

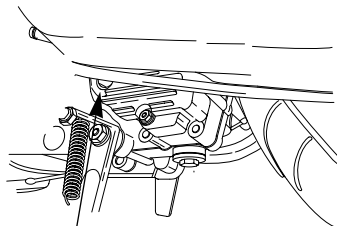

SIGHT GLASS

CAUTION

- Running the engine with insufficient oil may cause serious engine damage.

LIGHTS AND WINKER INSPECTION

<HEADLIGHT, TAILLIGHT>

Start the engine and make sure the lights turn on. Also check to see if the lights are damaged or if there is dirt on them.

<BRAKE LIGHT CHECK>

Turn the main switch to ON.

While separately operating the front and rear brakes, check to see if the brake light turns on. Also check to see if there is any damage to the lens or if there is dirt on the brake light.

<WINKER CHECK>

Turn the main switch to ON.

Check to see if all the winker in the front and rear of the vehicle(including left and right sides) are flashing properly, At the same time, check to make sure that the automatic sound signal of the winker is working. Check also to see if any of the lens are damaged or dirty.

BACK MIRROR INSPECTION

Sit squarely on the seat and check to see if you have a good view behind the vehicle by looking at the back mirrors. Also check for dirt and damage on the back mirrors.

FUEL LEAK INSPECTION

Check to see if there is any leaking fuel by thoroughly checking the fuel tank, hose, carburetor, etc.

CAUTION

- If any fuel is spilled, make sure the area is dry before starting the engine.

LICENSE PLATE INSPECTION

Check to see if there is any dirt or damage to the license plate.
Also check to see if the license plate is firmly secured to the vehicle.

MAINTENANCE

- The Required Maintenance Schedule specifies how often you should have your motorcycle served, and what things need attention.

It is essential that your motorcycle be served as scheduled to retain its high level of safety, dependability, and emission control performance.

- These instructions are based on the assumption that the motorcycle will be used exclusively for its designed purpose. Sustained high speed operation, or operation in unusually wet or dusty conditions, will require more frequent service than specified in the MAINTENANCE SCHEDULE.

Consult your authorized Daelim dealer for recommendations applicable to your individual needs and use.

MAINTENANCE SCHEDULE

Perform the Self Inspections Before Operation at each scheduled maintenance period.

I: INSPECT AND, CLEAN, ADJUST, LUBRICATE OR REPLACE IF NECESSARY

R: REPLACE L: LUBRICATE C: CLEAN

ITEM		FREQUENCY	ODOMETER READING(CAUTION 1)				REMARK	
			× 1,000Km	1	4	8		12
			MONTH		6	12		18
★	FUEL LINE		I	I	I	I		
★	FUEL FILTER		R	R	R	R		
★	THROTTLE OPERATION		I	I	I	I		
	AIR CLEANER		Every 1,000Km : C				NOTE(2)	
	SPARK PLUG			I	R	I		
★	VALVE CLEARANCE		I	I	I	I		
★	CARBURETOR IDLE		I	I	I	I		
★	ENGINE OIL		R	R	R	R		
★★	ENGINE OIL FILTER		R	R	R	R		
	OIL FILTER SCREEN			C	C	C		
	TRANSMISSION OIL					R	NOTE(3)	
★	BRAKE FLUID			I	I	I	NOTE(3)	

ITEM		FREQUENCY	ODOMETER READING(CAUTION 1)				REMARK	
			× 1,000Km	1	4	8		12
			MONTH		6	12		18
★	BRAKE SHOE / PAD WEAR		I	I	I	I		
	BRAKE SYSTEM		I	I	I	I		
★	BRAKE STOP SWITCH			I	I	I		
★	HEADLIGHT ADJUSTMENT		I	I	I	I		
★	SUSPENSION			I	I	I		
★	BOLTS, NUTS, FASTENERS		I		I			
★★	WHEELS / TIRES			I	I	I		
★★	STEERING HANDLE BEARING		I	I	I	I		
★★	DRIVE BELT			I	I	I		
★★	WEIGHT ROLLER			I	I	I		
★★	SLIDE PIECE			I	I	I		

★ If you do not have the appropriate tools or information to conduct maintenance, or if you feel you are not capable to perform maintenance on this vehicle, contact authorized dealers or repair shops for maintenance and repairs.

★★ To ensure safety, inspections and maintenance of these parts must be carried out by dealers, or repair centers.

NOTES : (1) At higher odometer readings, repeat at the frequency interval established here.

(2) Service more frequently when riding in unusually wet or dusty areas.

(3) Replace every 2 years, or at indicated odometer interval, whichever comes first. Replacement requires mechanical skill.

MAINTENANCE PRECAUTIONS

The following is an explanation of correct inspection methods, cleaning and parts replacing. Please always refer to this section when wanting to inspect or repair your vehicle.

WARNING

- If your motorcycle is overturned or involved in a collision, inspect control levers, cables, brake hoses, calipers, accessories, and other vital parts for damage. Do not ride the motorcycle if damage impairs safe operation. Have your authorized Daelim dealer inspect the major components, including frame, suspension and steering parts, for misalignment and damage that you may not be able to detect.
- Use new, genuine Daelim parts or their equivalent for maintenance and repair. Parts which are not of equivalent quality may impair the safety of your motorcycle and the effective operation of the emission control systems.

CAUTION

- Always observe safety rules when performing maintenance on the vehicle.
- Choose a flat surface and make sure the main stand is in a secure down position.
- Use correct tools.
- Conduct engine maintenance with the engine key out of the ignition.
- Be careful around the engine and muffler when performing maintenance as these areas can become extremely hot.
- After self maintenance, the waste material must be packed in the specified container and entrusted disposal to the authorized disposal company.

BRAKES

Both the front and rear brakes are the hydraulic disk type.

As the brake pads wear, the brake fluid level drops.

There are no adjustments to perform, but fluid level and pad wear must be inspected periodically.

The system must be inspected frequently to ensure there are no fluid leaks.

If the lever free play becomes excessive and the brake pads are not worn beyond the recommended limit, there is probably air in the brake system and it must be bled.

See your authorized Daelim dealer for this service.

CAUTION

- Brake fluid may cause irritation. Avoid contact with skin or eyes. In case of contact, flush thoroughly with water and can a doctor if your eyes were exposed.
- Keep out of reach of children.

<REPLENISHING FRONT BRAKE FLUID>

- Check that the fluid level is above the LOWER level mark with the motorcycle in an upright position.
- Brake fluid must be added to the reservoir whenever the fluid level begins to reach the LOWER level mark.

1. Remove the screw rivet and take the front brake fluid maintenance lid off.
2. Clean dust and other foreign materials around reserve tank to prevent foreign materials from falling inside tank.
3. Remove the screws and take oil cup cap, diaphragm plate, diaphragm off.
4. Replenish recommended brake oil to the upper level inside reserve tank.

**RECOMMENDED BRAKE OIL IS
DOT 3 or DOT 4**

5. Reinstall the diaphragm plate, and oil cup cap.
6. Tighten the screws securely.
7. Install the front brake fluid maintenance lid.

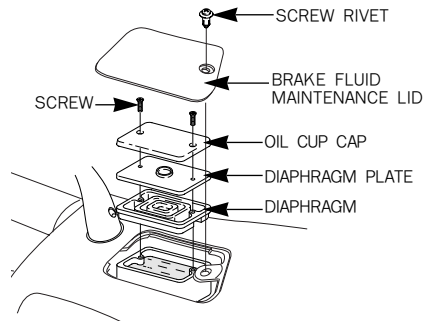

<REPLENISHING REAR BRAKE FLUID>

- Replenish in the same method as that of front brake fluid replenishment.

CAUTION

- When adding brake fluid, be very careful not to allow foreign matter to enter the reserve tank.
- Do not fill past upper level. This can cause brake fluid to leak out of the reserve tank.
- Do not let brake fluid contact vehicle parts as this damages painted areas. If oil contacts parts, quickly clean the fluid off using a dry cloth.
- Use recommended brake fluid as other types can undergo chemical changes.
- If brake fluid is exceedingly low, this can be indication of damage to the brake system.
- A leak in the brake system can lead to reduced braking efficiency and possible loss of braking ability.

BRAKE HOSE, PIPE LEAKAGE, DAMAGE, ASSEMBLY STATE

Visually check for fluid leaks or damage and, using a spanner, check joints and clamps for clearance.

Also, check hose and pipe protective parts to see if they contact other parts when turning the handle bars or due to vibration when driving.

BRAKE PAD WEAR

Brake pad wear depends upon the severity of usage, the type of riding, and road conditions. (Generally, the pads will wear faster on wet and dirty roads.)

Inspect the pads at each regular maintenance interval (page 32).

[FRONT / REAR BRAKE]

- Check the cutout in each pad.
- If either pad is worn to the cutout, replace both pads as a set
- See your authorized Daelim dealer for this service.

<FRONT BRAKE>

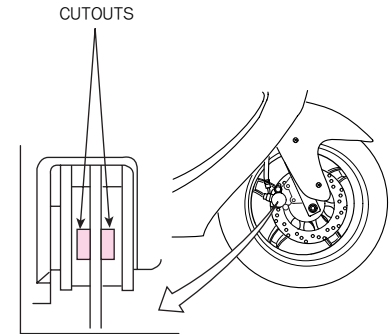

<REAR BRAKE>

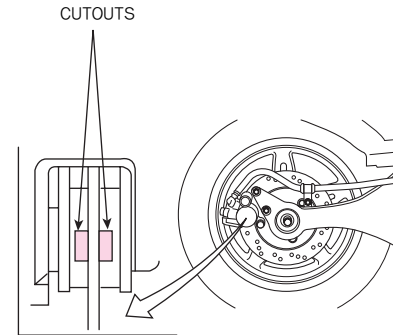

CHANGING ENGINE OIL

If engine oil is polluted, it seriously affects the engine life span. Maintain appropriate level of oil, use correct type of oil and observe oil exchange period.

- Stand vehicle on the main stand on level ground and run engine idle(warm-up) for approximately 2-3 minutes.
- Stop engine and place a container under the engine. Remove the drain plug bolt, and drain engine oil.
- Tighten the drain plug bolt.
- Remove the plug maintenance cover and fill the engine oil after opening oil filter cap of cylinder head cover.

**OIL CAPACITY : 0.8 l (After oil filter change)
0.75 l (After oil change)**

- Start the engine and keep it idle for a few minutes.
- Stop the engine and check the oil level. If the oil level is low, add the recommended engine oil.
- Check on oil leaks.

<RECOMMENDED OIL>

If oil sold on markets or privately manufactured oil (oil-grade) is used, engine life is adversely affected, and the privilege of warranty repairs cannot be guaranteed.



GRADE(SE, SF, SH)

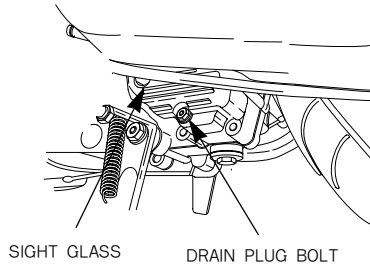

CAUTION

- If you change engine oil immediately after engine is stopped, be careful of burns because the engine, muffler and engine oil are still hot.
- Exercise caution not to allow dust or other foreign matter to flow in when refilling engine oil.
- If oil overflows, wipe off oil clean. If oil level is lower or higher than prescribed level, engine is adversely affected.
- Do not mix oil with those of different manufacturers or grade, or do not use low-quality oil as it may cause deterioration of oil, leading to accidents.
- Clean the oil filter screen with fresh cleaning oil every 4,000km.
- Be careful not to lose the oil filter screen spring when assembling the oil drain bolt.

WHEEL REMOVAL

[FRONT WHEEL REMOVAL]

- ① Raise the front wheel off the ground by placing a support block under the engine.
- ② Loosen the oval screw and remove the speedometer cable.

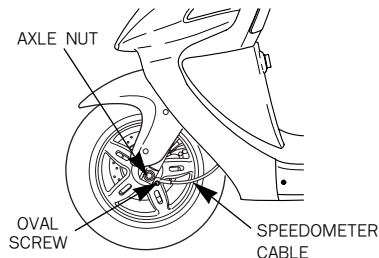

- ③ Remove the front caliper assembly from the front fork by removing the fixing bolts.

CAUTION

- Do not operate brake lever after the front wheel is removed. It will make wheel assembling difficult.

- ④ Loosen the axle nut.
- ⑤ Withdraw the front wheel axle and remove the front wheel.

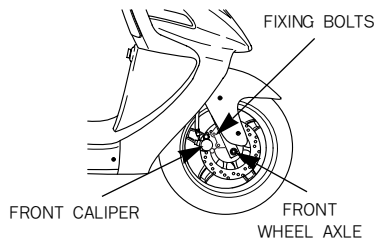

- ⑥ Install in the reverse order of removal.

CAUTION

- When installing the wheel, carefully fit the left brake disk between the brake pads to avoid damaging the pads.
- Prior to assembling, match the depressed part (凹) of the speedometer gear box with the projected part of the left front fork.

DEPRESSED PART

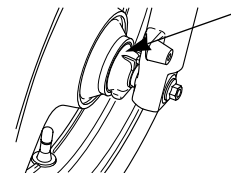

- Fit the caliper over the disc, taking care not to damage the brake pads. Install the caliper fixing bolts, and tighten to a torque of : **2.7kgf · m**
 - Tighten the front axle nut to the specified torque.
FRONT AXLE NUT TORQUE : 5.0~7.0kgf · m
- ⑦ After assembling, operate brake for a number of times and see if wheel is turning smoothly without getting interruption.

CAUTION

- If a torque wrench was not used for installation, see your authorized dealer as soon as possible to verify proper assembly.
Improper assembly may lead to loss of braking capacity.

<REAR WHEEL REMOVAL>

- ① Set vehicle on main stand in upright position on level ground.
- ② Loosen the rear brake hose setting bolt.
- ③ Loosen the 3 muffler setting bolts, and remove the muffler.

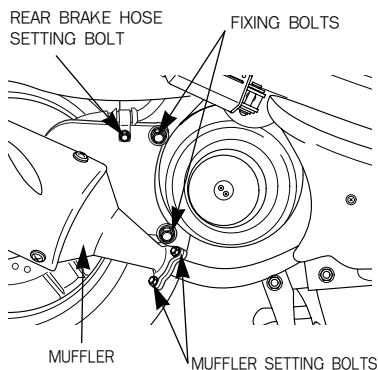

- ④ Loosen the rear brake hose setting bolt.
- ⑤ Remove the rear caliper assembly from the rear swing arm by removing the 2 fixing bolts.
- ⑥ Loosen the axle nut, remove the rear swing arm.
- ⑦ Remove the collar and the rear wheel.

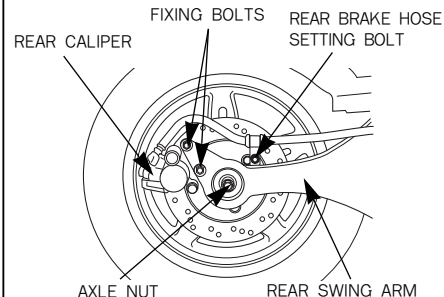

- ⑧ Install in the reverse order of removal.

REAR AXLE NUT TORQUE

: 6.0~8.0kgf · m

CAUTION

- If a torque wrench was not used for installation, see your authorized dealer as soon as possible to verify proper assembly.
Improper assembly may lead to loss of braking capacity.

SPARK PLUG

If electrode is stained or clearance is not right, satisfactory spark is not produced. Clean and make adjustment.

- Remove spark plug cap.
- Clean around the plug.
- Using a plug wrench, remove plug.
- Clean plug with plug cleaner.
- Check electrode for wear and corrosion.
- Measure clearance using a feeler gauge.

PLUG GAP: 0.8-0.9mm

- Tighten with hands until the plug washer touches cylinder head.

STANDARD PLUG: CR8EH-9

- If new plug is installed, turn 1/2 and tighten using a plug wrench.

If plug is reused, turn 1/3~1/4 and tighten.

CAUTION

- If plug of different maker or different heat value is used, it causes unsatisfactory engine starting, inadequate engine revolution and output deterioration.
- The spark plug must be securely tightened. An improperly tightened plug can become very hot and possibly damage the engine.

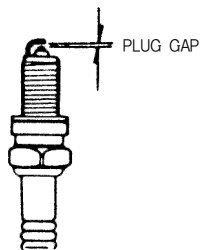

<DEALING WITH POOR STARTING>

When the starter doesn't work during driving in winter times or in a repeated short distance, use the suitable spark plug for this driving condition.

Poor starting may happen when nonstop driving in low speed, even though we produce standard plug.

In case starter isn't working well in driving repeatedly in a short distance or in an area with many traffic signals, use the CR7EH-9 plug instead of standard plug CR8EH-9

BATTERY INSPECTION

<CLEANING BATTERY TERMINALS>

- If you remove two screws from battery box cover after putting floor panel met forward, you will find battery assembled.
- If the battery terminal is polluted, or in rust, separate battery and clean it.
- Battery terminal in rust with white powder should be cleaned with warm water.
- In case of serious rust of battery terminal, disassemble the battery cord and grind it with wirebrush or sandpaper.

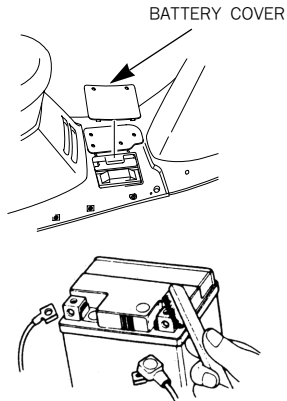

CAUTION

- Turn the ignition switch OFF before disconnecting the terminal from the battery. Remove the negative pole \ominus side cord first and the positive pole \oplus side cord next. Make sure, at this time, that \oplus side cord is connected first, followed by \ominus side cord.
- When handling the battery stay away from flammable materials.
- Make sure that terminals do not contact with other adjacent parts when handling \oplus/\ominus terminal. Contact with other parts may cause spark resulting in electrical equipment malfunction, fire and electric shock.
- Frequent cell starting can shorten the battery lifetime. Please use a kick to start the engine after the long period storage and in case of the initial starting and the cold starting to improve starting performance and extend the battery lifetime.

<REPLENISHING BATTERY WATER>

- This vehicle doesn't need either replenishing or checking battery water because of the equipment of enclosed MF battery.
- In case battery needs a checking, it should be cared of by service center.

CAUTION

- Be careful not to disassemble injection part of enclosed battery.
- When not using vehicle during a long time, take off the battery from the vehicle to keep from self-discharge and electric discharge. Put the battery in a well ventilated place after charging fully. In case it isn't available to take battery off from the vehicle, disconnect "-" terminal.

FUSE REPLACEMENT

Turn off the main switch to see if the fuse is severed. If the fuse is severed, exchange the fuse into 7A fuse.

- To change a fuse, first take off battery cover. Then, disconnect a “fuse connector” after opening a “fuse holder.”
- If the fuse immediately becomes severed after being changed with the new one, check another problem of the electric system.

<DISASSEMBLY>

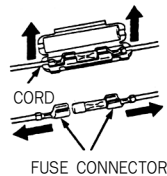

<ASSEMBLY>

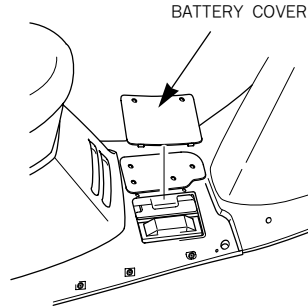

CAUTION

- Disassembly.
When disassemble fuse, make sure that fuse holder isn't separated.
- Assembly.
After assembling fuse in the part of connector, check if fuse moves easily to a line. If fuse moves easily, it may cause an accident at heating.
- Do not use a fuse having a larger voltage as the wire can become overheated and damaged.
When replacing any of the electrical parts (lights and gauges), be sure to replace them with the recommended parts. Using different parts can lead to the fuses burning out or damage to the battery.
- When washing the vehicle, take special care not to allow to be splashed in the area of the fuses.

BULB REPLACEMENT

- Be sure to turn the ignition switch OFF when replacing the bulb.
- Do not use bulbs other than that specified.
- After installing a new bulb, check that the light operates properly.

CAUTION

- The light bulb becomes very hot while the light is ON, and remain hot for a while after it is turned OFF. Be sure to let it cool down before servicing.
- Do not put finger prints on the headlight bulb, as they may create hot spots on the bulb and cause it to break. Wear clean gloves while replacing the bulb.
If you touch the bulb with your bare hands, clean it with a cloth moistened with alcohol to prevent its early failure.

[HEADLIGHT BULB]

- Before replacing the bulb, be sure to check the switches for loose connection of the connector.
- ① Loosen the special screw and remove the front cover.
 - ② Loosen the 4 headlight setting bolts and pull off the socket without turning.

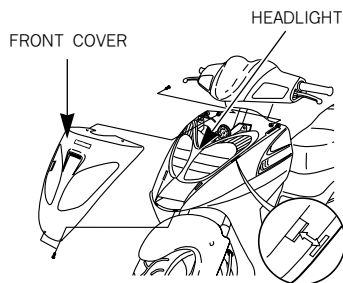

- ③ Remove the rubber cover.
- ④ Remove the pin.
- ⑤ Slightly press down on the bulb and turn it counterclockwise.
- ⑥ Install a new bulb in the reverse order of removal.

HEADLIGHT BULB : 12V35/35W

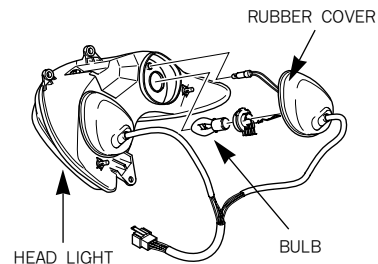

[TAIL/STOPLIGHT BULB]

- ① Remove the rear undercover.
- ② Loosen the 2 screws and remove the rear combination light lens.
- ③ Slightly press down on the bulb and turn it counterclockwise.
- ④ Install a new bulb in the reverse order of removal.

TAIL/STOP LIGHT BULB : 12V 21W/5W

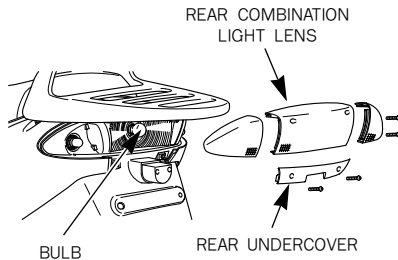

[WINKER BULB]

<FRONT WINKER BULB>

- ① Remove the RH./LH. back mirror.
- ② Loosen the 1 RH./LH. handle side cover lower screw, and 1 each of the special upper side screws.
- ③ Loosen the 4 rear handle cover screws.
- ④ Loosen the front handle cover setting screw.
- ⑤ Pull the front handle cover forward, and remove the wiring.
- ⑥ Remove the front handle cover.

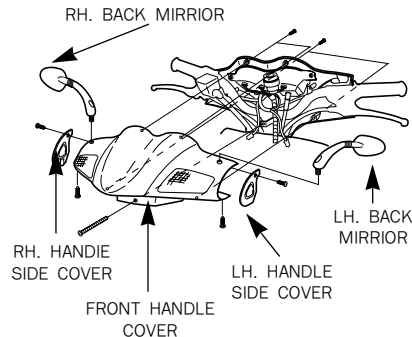

- ⑦ Loosen the screw and remove the socket.
- ⑧ Slightly press down on the bulb and turn it counterclockwise.
- ⑨ Install a new bulb in the reverse order of removal.

FRONT WINKER BULB : 12V 10W

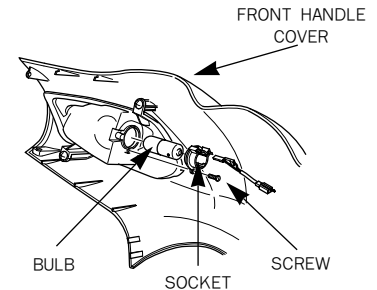

<REAR WINKER BULB>

- ① Remove the rear undercover.
- ② Loosen the 2 screws and remove the rear combination light lens.
- ③ Remove the rear winker lens.
- ④ Slightly press down on the bulb and turn it counterclockwise.
- ⑤ Install a new bulb in the reverse order of removal.

REAR WINKER BULB : 12V 10W

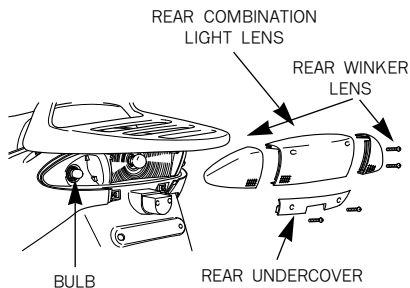

AIR CLEANER ELEMENT INSPECTION

<REMOVAL>

- ① Turn the seat lock switch to the right using the main switch key.
- ② Loosen the 6 washer screw and remove the air cleaner case cover.
- ③ Loosen the 2 washer screw and remove the air cleaner element holder.
- ④ Remove the air cleaner element.

<CLEANING>

- Clean the air cleaner element in clean oil, squeeze excess oil, and then, wrapping it in a dry cloth, squeeze it again.
- Make sure all excess oil removed and reassemble the air cleaner element.

OIL : SAE 10W-30

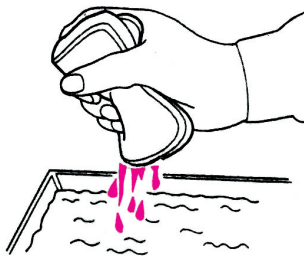

- ⑤ Install in the reverse order of removal.

CAUTION

- Do not use gasoline or other materials having a low ignition point as this can be a fire hazard.
- If the air cleaner element is in adequately assembled, dust and other waste materials can directly enter the engine. This results in increased cylinder wear and reduced power, and reduced durability of the engine.
- When washing the vehicle, be careful not to allow water to get into the air cleaner. Difficulties in starting the engine may result if this happens.
- If the engine start is failed during rain or after driving across water pool, check to see if the water is infiltrated in the air cleaner and clean it.

SIDE STAND INSPECTION

- Erect main stand and place vehicle in upright position on level ground.
 - Check the spring for damage or loss of tension and the side stand assembly for freedom of movement.
 - Check the side stand ignition cut-off system;
- ① Put the side stand up.
 - ② Start the engine.
 - ③ Lower the side stand. The engine should stop as you put the side stand down.
- If the side stand system does not operate as described, inspect it in the closest authorized repair center.

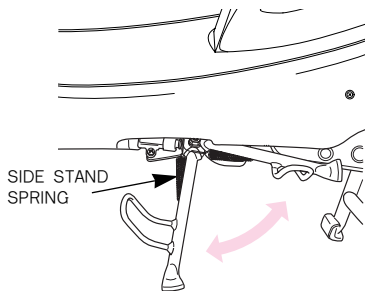

CABLE RUBBER PART INSPECTION

A rubber part is assembled on the cable to protect the inner cable. Make sure that this part is placed firmly around the correct part of the cable. When washing the car, do not directly spray water on to the rubber part is dirty, use a dry cloth to clean this area.

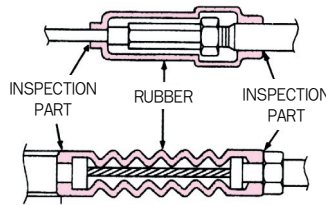

CAUTION

- Infiltration of the foreign materials or water caused by damage of lever (disengagement, tearing, etc.) may cause freezing in winter season resulting in faulty operation, sudden acceleration and braking force decrease. If any damage is found, replace with the new one immediately.

NOTABLES FOR CAR WASHING

- Make sure to stop the engine prior to car washing.
- Be careful not to allow water to enter the muffler during the washing. Water inside the muffler may cause an improper engine starting or rust occurrence.
- Do not let water get inside the braking system during the washing, as water inside the brake system may weaken the braking power. Upon completion of washing, select a safe place where there is no traffic obstruction, and start the vehicle. Lightly apply the brake while driving at a slow speed and check the braking power. If the braking power has been weakened, apply brake lightly while driving at a slow speed to dry up the brake system.
- Take precautions when waxing the vehicle. Excessive polish of the painted section and/or the resin part with compound wax might damage the painted section causing discoloration of the affected area.

STORAGE GUIDE

Extended storage, such as for winter, requires that you take certain steps to reduce the effects of deterioration from non-use of the motorcycle.

In addition, necessary repairs should be made **BEFORE** storing the motorcycle; otherwise, these repairs may be forgotten by the time the motorcycle is removed from storage.

<STORAGE>

- Empty the fuel tank into an approved gasoline container using a commercially available hand siphon or an equivalent method.
- If storage will last more than one month, carburetor draining is very important, to assure proper performance after storage.

CAUTION

- Gasoline is extremely flammable and is explosive under certain conditions. Perform this operation in a well-ventilated area with the engine stopped. Do not smoke or allow flames or sparks in the area where gasoline is drained or stored and where the fuel tank is refueled.
- Remove the battery. Store in an area protected from freezing temperatures and direct sunlight. Slow charge the battery once a month.
- Wash and dry the motorcycle. Wax all painted surfaces.

- Inflate the tires to their recommended pressures. Place the motorcycle on blocks to raise both tires off the ground.
- Cover the motorcycle (don't use plastic or other coated materials) and store in an unheated area, free of dampness with a minimum of daily temperature variation. Do not store the motorcycle in direct sunlight.

<REMOVAL FROM STORAGE>

- Uncover and clean the motorcycle.
- Charge the battery as required. Install the battery.
- Perform all Self Inspections Before Operation checks (page 25).
Test ride the motorcycle at low speeds in a safe riding area away from traffic.

FRAME AND ENGINE NUMBER

- The frame number is stamped on the front central part of the frame.
- The engine number is stamped on the central part of the left crankcase.
- The frame and engine numbers will be used as the basis of recovering the vehicle when it is stolen.
- Record the frame and engine numbers along with the vehicle license plate numbers and keep them separately from the vehicle.

<FRAME NUMBER>

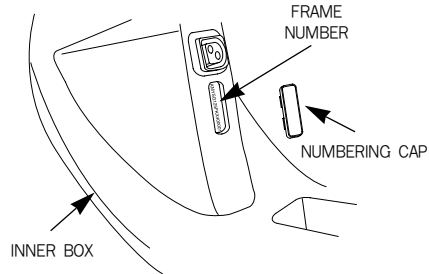

<ENGINE NUMBER>

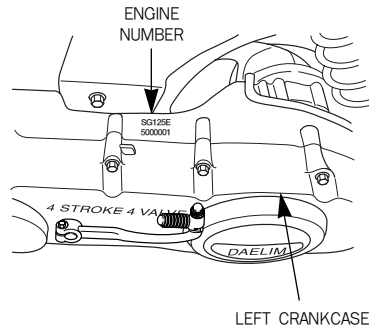

SAFE DRIVING



PREPARATION BEFORE DRIVING

- Performing daily inspection
- Putting on the protective gears (Helmet, glove, goggles, etc.)
- Bringing the driver's licence
- Determinating the path to the desired destination

DRIVING METHOD

DRIVING POSITION

< SCOOTER >

The appropriate driving position is most important thing to driving safely.

- ① Eyes : Look at the front direction widely.
- ② Shoulders : Relieve the tension.
- ③ Arms : Relieve the tension and bend arms to inside and let them act as the spring.
- ④ Hands : Grip the handle the position away from the inside end of the handle with distance of one finger to facilitate the operation of the switch and lever.
- ⑤ Wrist : Keep the state to act freely without applying excessive force to the shoulder and arms.
- ⑥ Knees : Relieve the tension and keep the distance of both knee same as shoulders.
- ⑦ Feet : Place the feet to face the front parallel and keep the distance of both feet same as shoulders

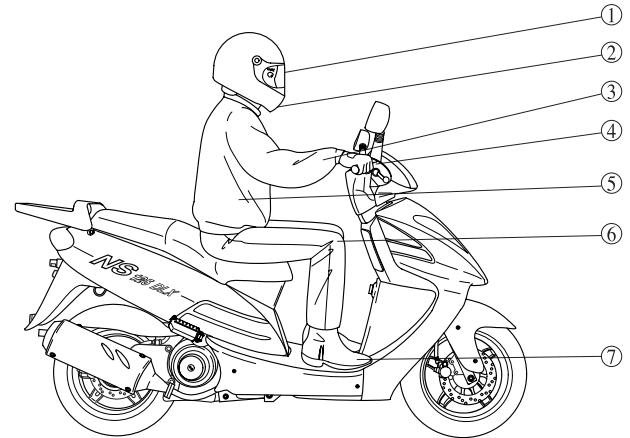

< VEHICLE EXCEPT SCOOTER >

- ① Eyes : Look at the front direction widely.
- ② Shoulders : Relieve the tension.
- ③ Arms : Relieve the tension and bend arms to inside and let them act as the spring.
- ④ Hands : Grip the handle the position away from the inside end of the handle with distance of one finger to facilitate the operation of the switch and lever.
- ⑤ Wrist : Keep the state to act freely without applying excessive force to the shoulder and arms.
- ⑥ Knees : Press the fuel tank slightly.
- ⑦ Feet : Place the feet to face the front parallel and make the step bar be placed in the center of feet.

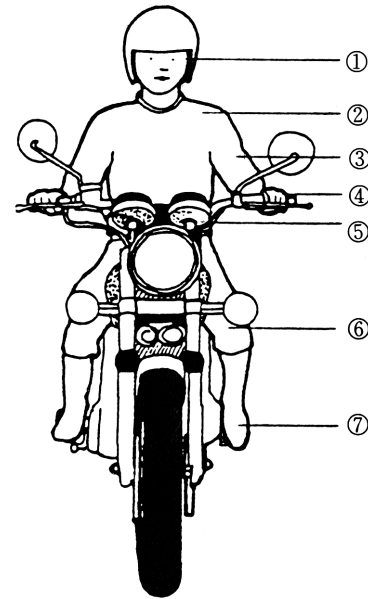

PRECAUTION WHEN DRIVING

- Secure the safe distance.
 - Drive protectively.
 - Do not obstruct the traffic.
 - Do not drive on the pedestrian way or walkway.
 - Drive on the left driveway when passing away.
 - Make sure that you can apply the brake anytime.
 - Always apply the brake when stopping temporarily.
 - Do not drive excessively long distance and take enough break.
- If any abnormality is found, stop driving and contact service center to inspect the vehicle.
 - Restart the vehicle after 2~3 min when it is turned over.
 - Always turn on the headlight at night.

STARTING

Prior to starting always look around to avoid accident.

< SCOOTER >

- ① Lock the rear brake with the main stand erected.
- ② Start the engine using the cell or kick.
- ③ Pull back the main stand.
- ④ Get on the vehicle.
- ⑤ Release the brake lock lever by pull the rear brake lever strongly.
- ⑥ Start driving slowly after turning on the winker and releasing the brake while ensuring the safety around the vehicle.

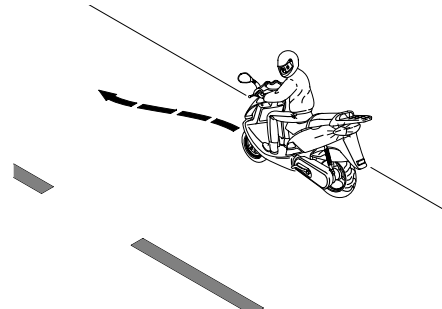
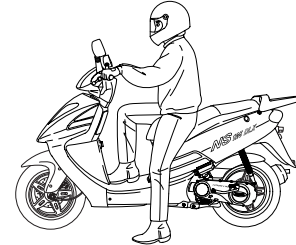
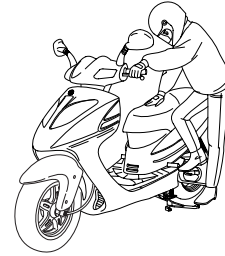

< VEHICLE EXCEPT SCOOTER >

- ① Get on the vehicle after pulling back the stand.
- ② Start driving slowly after turning on the winker and releasing the brake while ensuring the safety around the vehicle.

CAUTION

- Return the side stand to its original position.
- Keep driving without doing this may cause turnover accident.

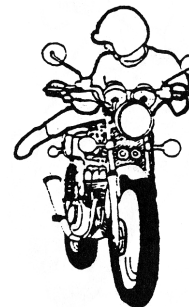
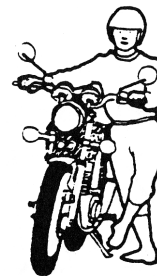

TURNING METHOD

PRINCIPLE OF TURN

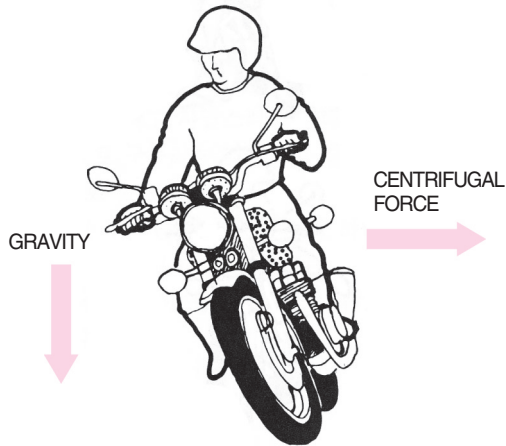

The basic principle of turn is balancing using the centrifugal force which makes vehicle go outside and the gravity which makes vehicle fall inside.

EFFECT OF SPEED

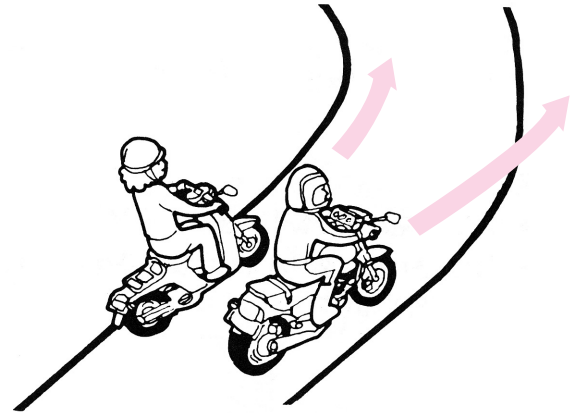

The centrifugal force increases in inverse proportion to the radius of a curve and in proportion to the square speed. Decelerate prior to entering the curved way to reduce the centrifugal force.

3 POSITIONS OF TURNING

The basic principle of turn is balancing using combined force of the centrifugal force and the gravity.

All 3 positions require straightening the head and keeping the eyes horizontally.

< LEAN-WITH >

This is a turning position with motor cycle and driver in a line. This position is the most natural and exact, so driver must learn it thoroughly.

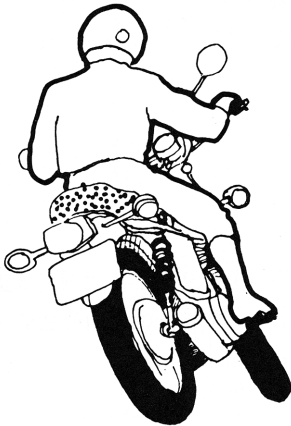

< LEAN-IN >

This is a turning position with driver leaned inside more than motor cycle. This position is adequate to drive on the rained or slippery road because it has best road holding.

However, special attention is required because front visual field is poor when driver leans inside more than motor cycle.

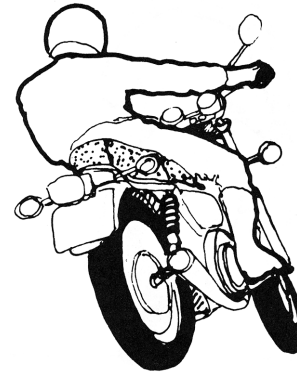

< LEAN-OUT >

This is a turning position with motor cycle leaned inside more than driver, which is opposite to the lean-in position. With this position, quick turn is well performed and driver can obtain wide front visual field adequate to drive on the rained or slippy road because it has best road holding. However, special attention is required because there is danger of slipping on the bad holding road.

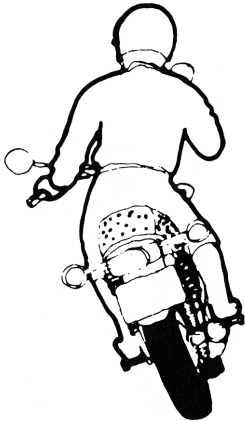

TURNING METHOD

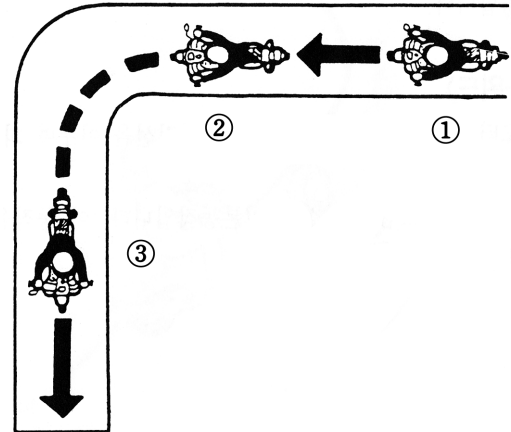

- ① Turn the throttle grip to its original position and decelerate using both front and rear brakes.
- ② Lean the vehicle toward inside of turn circle while driving slowly at constant speed.
- ③ Accelerate gradually.

PRECAUTION WHEN TURNING

Do not drive inside of large truck's turn circle.

< DEAD ANGLE ZONE >

Dead angle zone is the sight range which cannot be identified by driver and increases in proportion to the width of the vehicle

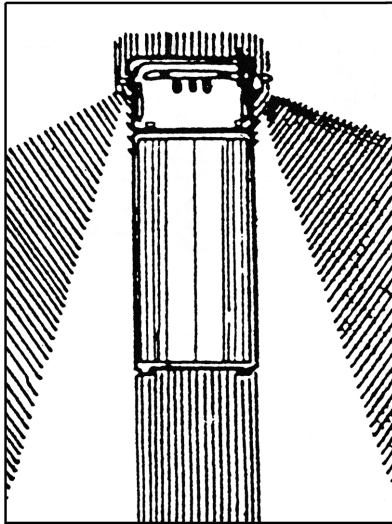

< DISTANCE BETWEEN THE FRONT AND REAR WHEEL TURN >

It is distance between path of the front and rear wheel and increases in proportion to the length of the vehicle

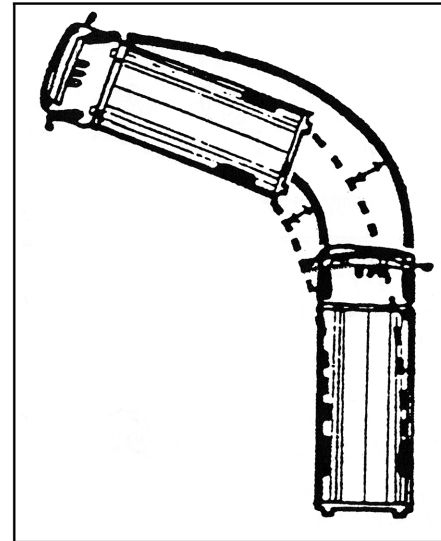

BRAKING METHOD

BASIC PRINCIPLE OF BRAKE (FRICTION FORCE)

- Vehicle is braked using friction between road surface and tires.
- Braking distance increases 1.5 times on wet road and 3 times on icy road because friction force of road surface is decreased.



RESTRAINT OF BRAKE EFFECT (INERTIA)

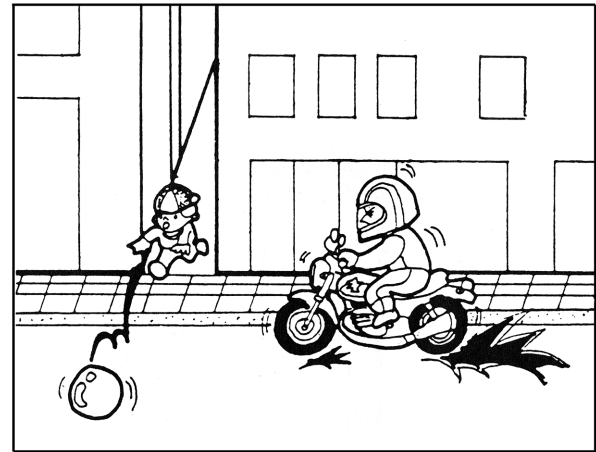

Due to the inertia, vehicle does not stop immediately after applying the brake.

BRAKING METHOD

- Turn the throttle grip to its original position and decelerate using the engine brake.
- Erect the vehicle straight.
- Brake using both front and rear brakes.

COMPARISON OF BRAKING DISTANCE

· Vehicle speed : 50 km/h



When using both front and rear brakes



When using only front brake



When using only rear brake

IMPACT WHEN COLLISION

Learn the proper braking method to prevent accident.

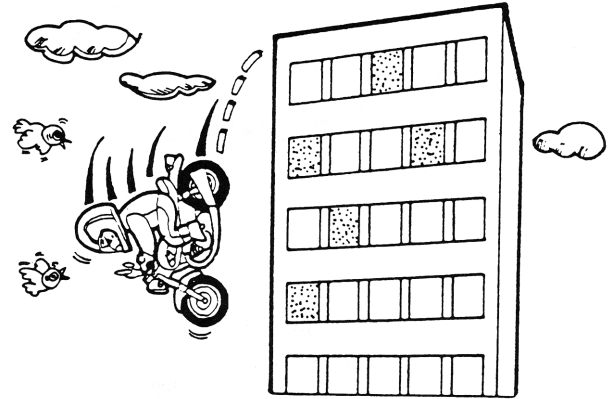

Impact increases in proportion to the speed and weight. The impact when collision to concrete wall at 50 km/h is same as one when falling from the height of 10m.

WIRING DIAGRAM

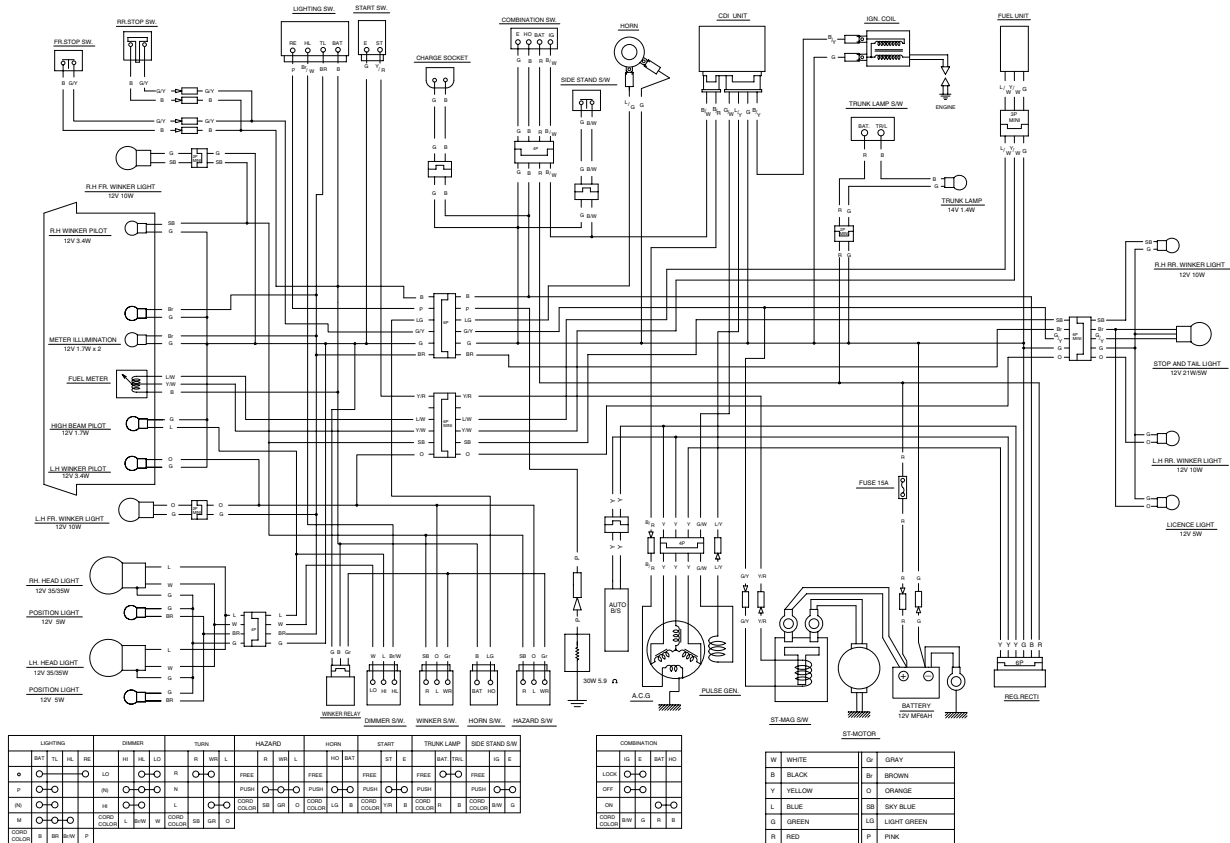

Lighting	Dimmed	Turn	Hazard	Horn	Start	Trunk Lamp	Side Stand Sw
BAT TL HL RC	RL RL LO	RL RL LO	FREE	FREE	FREE	FREE	FREE
P	RL RL	RL RL	PUSH	PUSH	PUSH	PUSH	PUSH
RL	RL RL	RL RL	CORO	CORO	CORO	CORO	CORO
W	RL RL	RL RL	CORO	CORO	CORO	CORO	CORO
CORO	RL RL	RL RL	CORO	CORO	CORO	CORO	CORO

Combination
LOCK
OFF
ON
CORO

W WHITE	GR GRAY
B BLACK	BR BROWN
Y YELLOW	O ORANGE
L BLUE	SB SKY BLUE
G GREEN	LG LIGHT GREEN
R RED	P PINK

MEMO

MEMO

A memo template with a double-line border and rounded corners. The word "MEMO" is centered at the top. The main body of the memo is filled with alternating horizontal bands of light gray and white, creating a striped effect. There are 10 such bands in total, starting with a light gray band at the top.

MEMO

A memo template with a double-line border and rounded corners. The page is divided into horizontal bands: a white header band at the top, followed by a series of alternating shaded and unshaded bands. There are 10 shaded bands and 9 unshaded bands, creating a total of 19 rows for writing. The word "MEMO" is centered at the top of the page.

MEMO

A memo template with a double-line border and rounded corners. The word "MEMO" is centered at the top. Below it, the page is filled with horizontal rows. Each row consists of a shaded gray band followed by an unshaded white band, creating a striped pattern for writing.

NS 125 DLX

OWNER'S MANUAL

2002. 1. PRINTED
2001. 1. PUBLICATION

NO COPY



DAELIM MOTOR CO.,LTD.